

Hydro Logic Products

Pond & Lake Aeration plus Aquatic Products

AirLift 1XL Aeration System

by **Hydro Logic Products**

AirLift 1XL™



X 1 = 1 AirPod XL Diffuser



SPECIFICATIONS

Pond & Lake AirLift XL™ Aeration Benefits:

- Increase Dissolved Oxygen Concentrations
- Eliminate Stress to Fish & Aquatic Organisms
- Increase Water Clarity (Transparency)
- Reduce Harmful Algal Blooms (HAB - Algae)
- Reduce High Metal Concentrations
- Reduce Nutrient Releases by Anoxic Sediments
- Reduce Buildup of Poisonous Gases
- Reduce Release of Noxious Odors
- Reduce the Accumulation of Sediments
- May Reduce Nuisance Levels of Aquatic Plants
- No Electricity in the Water
- Warranties on all System Components

Hydro Logic Products® AirLift 1XL™ pond and lake aeration systems are designed and built to cost effectively mix and aerate ponds and lakes. Our systems use billions of micron sized bubbles to improve pond and lake water quality. Our AirLift 1XL™ aeration system can aerate ponds and lakes up to 3-acres in size depending on air diffuser placement, nutrient concentrations, biological oxygen demand (BOD), water depth and other physical characteristics of the waterbody.

Our AirLift 1XL™ aeration system is powered by a 1/2 H.P. energy efficient, dual piston air compressor equipped with our proprietary SureStart™ technology. Our dual piston air compressor, which can deliver air under high pressures (water depths up to 50 feet), operates very quietly (55 decibels at 2 meters or 6 feet). In comparison, the noise levels of our air compressors are about 15 decibels less than equivalent rotary vane air compressors.

Our AirLift 1XL™ aeration system contains one AirPod XL™ air diffuser. The AirPod XL™ contains two (2) self-cleaning 20-inch tube, EPDM flexible membrane air diffusers equipped with a triple check valve system. Our air diffusers are constructed to withstand total airflow from the compressor without damaging the EPDM membrane (unlike EPDM disc air diffusers). The base of the AirPod XL™ provides a large surface area between the EPDM membrane and the sediments, thereby preventing sediment disturbance during system operation. The AirPod is extremely easy to install. Simply fill the two ballast tubes with pea gravel or sand prior to their placement in the pond or lake.

Compressed air from our dual piston compressor is delivered to the AirPod XL™ using our DownUnder™ self-weighted tubing. DownUnder™ air supply tubing is constructed of a flexible PVC composite and is kink proof and puncture resistant. Our easy to install tubing comes in several different lengths and diameters to meet your installation needs.

P.O. Box 605 Doylestown, PA 18901- 0605

Phone: 215.230.9325 ••• Fax: 215.230.9326 ••• www.HydroLogicProducts.com

Hydro Logic Products

Specifications – AirLift 1XL Aeration System

Page 2

COMPRESSOR (Drawing on Page 4)

- 1/2 HP dual piston air compressor with integral thermal motor overload protection
- Produces high airflow volumes (4.6 cfm) & operates under high pressures (40 psi max.)
- Oil-less air compressor that is virtually maintenance free
- **SureStart™** technology allows air compressor to restart under pressure after power outages
- High air pressure allows diffusers to be cleaned in ponds or lakes (unlike rotary vane compressors)
- U.L. listed 120 or 240 volt (5.3 or 2.7 amps) under full load
- 5-micron air filter maximizes air compressor life expectancy
- Easy field repairs - plumbing connections with push-on style fittings & flexible 100 psi tubing
- Noise reduction - mounted on cylindrical vibration pads & connected to flexible tubing
- Extremely quiet operation (55 decibels @ 2 meters or 6 feet @ 20 psi)
- Two-year warranty (best in the industry)

Our dual piston air compressor (240 volt option available) is outfitted with our proprietary **SureStart™** technology. This allows automatic restart of the air compressor under full pressure during any power outage (blackouts or brownouts) without damaging the air compressor motor. The air compressor is oil-less, thermally protected and requires no lubrication. The air compressor includes rotors/stators manufactured with the most advanced magnetic materials, sealed heavy-duty precision bearings and starting capacitor. The only required routine maintenance is periodically changing the 5-micron air filters. The compressor typically can operate approximately 3 years or more before any decline in performance is observed. This is 2 to 3 times better performance over standard piston, diaphragm and rotary vane compressors. Thereafter, the air compressor can be easily serviced by replacing the piston seals. Airflow versus pressure performance curves for our dual piston compressor varies less than for diaphragm and rotary vane compressors. This simply means that means that our dual piston compressor provides more air while using less energy. Lastly, our dual piston air compressor can operate under high pressures, thereby allowing the air diffuser membrane to be easily cleaned without pulling the AirPod from the pond or lake.

CABINET (Drawing on Page 4)

- Commercial grade, 14-gauge steel cabinet that is rustproof & vandal resistant
- Powder coated, forest green finish to blend into its surroundings
- Easy access design with lock & key for added security
- 6½ foot 3 prong plug for easy connection to standard 2-pole 3 wire 15A/20A electrical outlet
- Electrical circuits are Class "A" GFCI protected with a trip 4-6mA trip rating
- Ball bearing fan-cooled to maximize life of air compressors
- **SuperCool™** dual cooling fans available for very hot conditions or climates (optional)
- Liquid-filled pressure gauge
- Adjustable pressure relief valve
- Manifold equipped with sealed valves to precisely control the airflow to AirPod diffusers
- Heavy duty (24"L x 24"W x 2"H) HDPE mounting pad included
- Overall dimensions (24"L x 24"W x 24.6"H)
- Five-year warranty (best in industry)

Hydro Logic Products

Specifications – AirLift 1XL Aeration System

Page 3

The commercial-grade cabinet is constructed of 14-gauge steel with forest green electro-statically bonded powder coating. The cabinet is manufactured with a stamped ventilation intake grill and low resistance exhaust plenum (duct work). The cabinet comes equipped with sealed ball bearing cooling fan to maximize air compressor life and Class “A” GFCI Protection on all circuits. All cabinet components are easily disassembled using standard household tools. The cabinet includes a 5-year warranty against rust and corrosion and a 2-year warranty on all components mounted inside of the cabinet.

AirPod XL™ Air DIFFUSER (Drawing on Page 4)

- One AirPod XL equipped with two (2) flexible, fine pore EPDM rubber membrane tube diffusers
- More durable than air stone, porous media & EPDM disc diffusers
- Produces extremely fine air bubbles (500 – 1,000 micron or 0.020 - 0.040 inch)
- Triple check valve prevents water & sediment from entering the air supply line
- One EPDM tube diffuser is 20% larger than two 9-inch EPDM disc diffusers
- Self-cleaning & very low maintenance
- Large HDPE base (20”L x 15”W) to prevent sediment disturbance
- All AirPod XL components are corrosion resistant using PVC, fiberglass & HDPE materials
- Five-year warranty (best in the industry)

The **AirPod XL™** air diffuser contains two (2) self-cleaning 20-inch, EPDM flexible membrane tube diffusers equipped with a **triple check valve system**. The triple check valve prevents water and sediment from flowing back into the air supply line during system shut down. The EPDM tube air diffuser is mounted to heavy-duty PVC strut with ratcheting tie downs to provide easy assembly/disassembly. The above components are secured to a large HDPE base. Two hollow ballast tubes are anchored beneath the base. The ballast tubes are designed so that pea gravel or sand can be easily added to these tubes during installation.

DownUnder™ SELF-WEIGHTED AIR SUPPLY TUBING

- Over-sized 0.58 inch I.D. for low-pressure drop applications*
- Heavy-duty wall thickness for durability
- Self-weighted for easy installation
- Kink proof & puncture resistant
- Available in 100 ft. (boxed) & both 200 & 500 ft. (rolls) lengths
- 10-year warranty (best in the industry)

* DownUnder™ air supply tubing is also available in 0.375 in. I.D. for smaller pond and lake applications

DownUnder™ air supply tubing is constructed of a flexible PVC composite and is self-weighted in order to firmly remain along the pond or lake bottom after the installation. Sections of DownUnder™ tubing are connected together using standard PVC solvent weld cement and ½ inch insert fittings. DownUnder™ air supply tubing has low friction walls for maximizing airflow rates and minimizing air pressure drops. Our DownUnder™ tubing is designed to reduce the overall system pressure requirements and to extend the life of the air compressors. The wall thickness provides long-term durability and protection against kinking and punctures. The air supply tubing remains flexible in cold temperatures allowing for easy year round installations.

Drawings

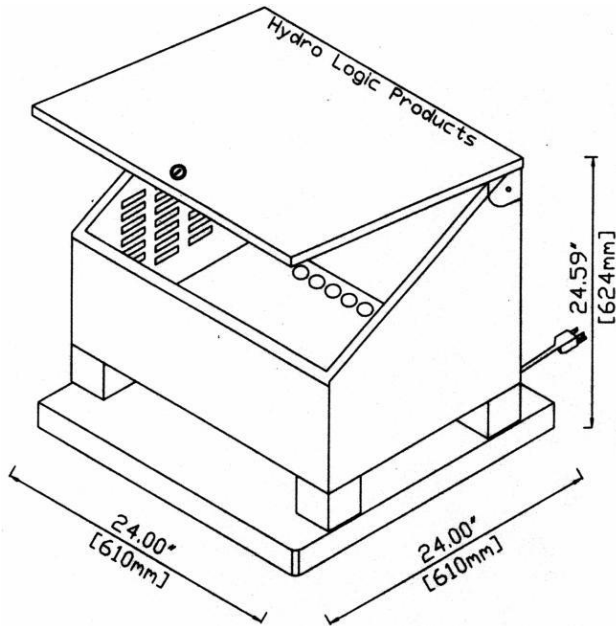

Air Compressor Cabinet

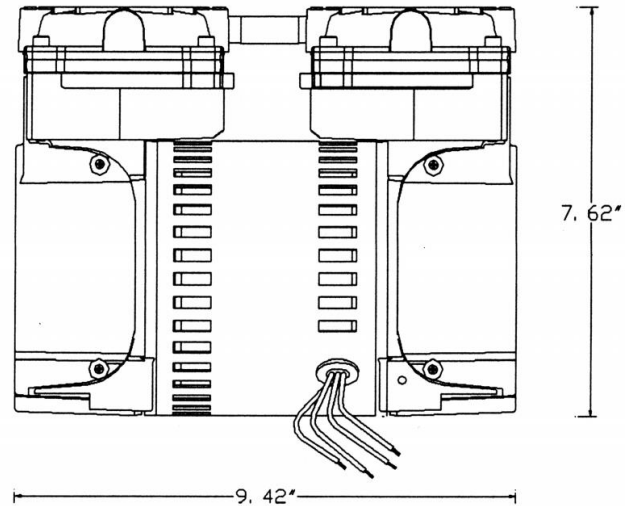

**Dual Piston Air Compressor
Side View**

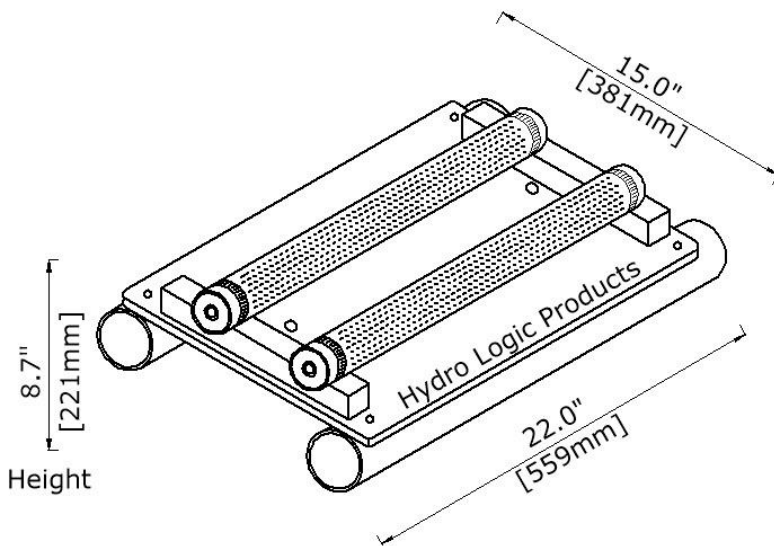

**AirPod XL
Air Diffuser**

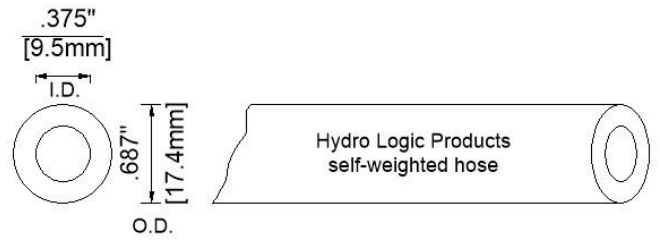

Available in 100ft boxes and 500ft reels.

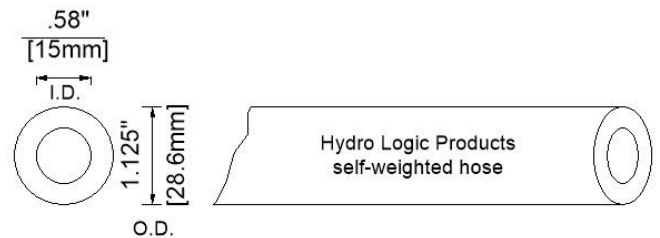

Available in 100ft boxes, 200ft and 500ft reels.

**DownUnder Self-Weighted
Air Supply Tubing**

Important Notice: Install all electrical equipment in accordance with Article 680 of the National Electrical Code and all local codes. Hydro Logic Products reserves the right to improve and change our aeration system designs and/or specifications without notice or obligation.