

# Hydro Logic Products

Pond & Lake Aeration plus Aquatic Products

## AirLift 10 HF Aeration System

by Hydro Logic Products

# AirLift 10 HighFlow™



X 10 = 10 AirPod Diffusers



HighFlow™  
Large Lake Series



## SPECIFICATIONS

### Large Lake AirLift™ Aeration Benefits:

- Increase Dissolved Oxygen Concentrations
- Eliminate Stress to Fish & Aquatic Organisms
- Increase Water Clarity (Transparency)
- Reduce Harmful Algal Blooms (HAB - Algae)
- Reduce High Metal Concentrations
- Reduce Nutrient Releases by Anoxic Sediments
- Reduce Buildup of Poisonous Gases
- Reduce Release of Noxious Odors
- Reduce the Accumulation of Sediments
- May Reduce Nuisance Levels of Aquatic Plants
- No Electricity in the Water
- Warranties on all System Components

Hydro Logic Products® AirLift 10 HighFlow™ large lake aeration systems are designed and built to cost effectively mix and aerate lakes. Our systems use billions of micron sized bubbles to improve pond and lake water quality. Our AirLift 10 HighFlow™ aeration system can aerate ponds and lakes up to 22+ acres in size depending on air diffuser placement, nutrient concentrations, biological oxygen demand (BOD), water depth and other physical characteristics of the waterbody.

Our AirLift 10 HighFlow™ aeration system is powered by two (2) 1 H.P. energy efficient, dual piston air compressors equipped with our proprietary SureStart™ technology. Our dual piston air compressors, which can deliver air under high pressures (water depths over 50 feet), operate very quietly (55 decibels at 2 meters or 6 feet). In comparison, the noise levels of our air compressors are about 15 decibels less than equivalent rotary vane air compressors.

Our AirLift 10 HighFlow™ aeration system contains ten (10) AirPod™ air diffusers. Each AirPod™ contains a self-cleaning 20-inch tube, EPDM flexible membrane air diffuser equipped with a **triple check valve** system. Our air diffusers are constructed to withstand total airflow from the compressor without damaging the EPDM membranes (unlike EPDM disc air diffusers). The base of the AirPod™ provides a large surface area between the EPDM membrane and the sediments, thereby preventing sediment disturbance during system operation. The AirPods are extremely easy to install. Simply fill the two ballast tubes with pea gravel or sand prior to their placement in the pond or lake.

Compressed air from our dual piston compressors are delivered to the AirPods using our DownUnder™ self-weighted tubing. DownUnder™ air supply tubing is constructed of a flexible PVC composite and is kink proof and puncture resistant. Our easy to install tubing comes in several different lengths and diameters to meet your installation needs.

P.O. Box 605 Doylestown, PA 18901- 0605

Phone: 215.230.9325 ••• Fax: 215.230.9326 ••• [www.HydroLogicProducts.com](http://www.HydroLogicProducts.com)

## **Hydro Logic Products**

### **Specifications – AirLift 10 HighFlow Aeration System**

Page 2

## **COMPRESSORS** (Drawing on Page 4)

- **Two (2) 1 HP dual piston air compressors** with integral thermal motor overload protection
- Produce high airflow volumes (15 cfm combined) & operate under high pressures (45 psi max.)
- Oil-less air compressors that are virtually maintenance free
- **SureStart™** technology allows air compressors to restart under pressure after power outages
- High air pressure allows diffusers to be cleaned in ponds or lakes (unlike rotary vane compressors)
- U.L. listed 240 volt (8.2 amps combined) under full load
- 5-micron air filters maximize air compressor life expectancy
- Easy field repairs - plumbing connections with push-on style fittings & flexible 100 psi tubing
- Noise reduction - mounted on cylindrical vibration pads & connected to flexible tubing
- Extremely quiet operation (55 decibels @ 2 meters or 6 feet @ 20 psi)
- Two-year warranty (best in the industry)

All of our dual piston air compressors are outfitted with our proprietary **SureStart™** technology. This allows automatic restart of our air compressors under full pressure during any power outage (blackouts or brownouts) without damaging the air compressor motors. Each air compressor is oil-less, thermally protected and requires no lubrication. All air compressors include rotors/stators manufactured with the most advanced magnetic materials, sealed heavy-duty precision bearings and starting capacitors. The only required routine maintenance of our air compressors is periodically changing the 5-micron air filters. Our air compressors typically can operate approximately 3 years or more before any decline in performance is observed. This is 2 to 3 times better performance over standard piston, diaphragm and rotary vane compressors. Thereafter, our air compressors can be easily serviced by replacing the piston seals. Airflow versus pressure performance curves for our dual piston compressor varies less than for diaphragm and rotary vane compressors. This simply means that our dual piston compressors provide more air while using less energy. Lastly, our dual piston air compressors can operate under high pressures, thereby allowing the air diffuser membranes to be easily cleaned without pulling the AirPods from the pond or lake.

## **CABINET** (Drawing on Page 4)

- Commercial grade, 14-gauge steel cabinet that is rustproof & vandal resistant
- Powder coated, forest green finish to blend into its surroundings
- Easy access design with lock & key for added security
- Ball bearing fan-cooled to maximize life of air compressors
- **SuperCool™ dual cooling fans** (470 cfm) included to further improve air compressor longevity
- Liquid-filled pressure gauge
- Adjustable pressure relief valve
- Manifold equipped with sealed valves to precisely control the airflow to AirPod diffusers
- Heavy duty (24”L x 24”W x 2”H) HDPE mounting pad included
- Overall dimensions (24”L x 24”W x 24.6”H)
- Five-year warranty (best in industry)

## Hydro Logic Products

### Specifications – AirLift 10 HighFlow Aeration System

#### Page 3

The commercial-grade cabinet is constructed of 14-gauge steel with forest green electro-statically bonded powder coating. The cabinet is manufactured with a stamped ventilation intake grill and low resistance exhaust plenum (duct work). The cabinet comes equipped with sealed ball bearing cooling fan to maximize air compressor life. All cabinet components are easily disassembled using standard household tools. The cabinet includes a 5-year warranty against rust and corrosion and a 2-year warranty on all components mounted inside of the cabinet.

### AirPod™ Air DIFFUSERS (Drawing on Page 4)

- Ten (10) AirPods each equipped with single flexible, fine pore EPDM rubber membrane tube diffuser
- More durable than air stone, porous media & EPDM disc diffusers
- Produces extremely fine air bubbles (500 – 1,000 micron or 0.020 - 0.040 inch)
- Triple check valves prevent water & sediment from entering the air supply lines
- One EPDM tube diffuser is 20% larger than two 9-inch EPDM disc diffusers
- Self-cleaning & very low maintenance
- Large HDPE base (20”L x 15”W) to prevent sediment disturbance
- All AirPod components are corrosion resistant using PVC, fiberglass & HDPE materials
- Five-year warranty (best in the industry)

Each AirPod™ air diffuser contains a self-cleaning 20-inch, EPDM flexible membrane tube diffuser equipped with a **triple check valve system**. The triple check valves prevent water and sediment from flowing back into the air supply lines during system shut down. The EPDM tube air diffuser is mounted to heavy-duty PVC strut with ratcheting tie downs to provide easy assembly/disassembly. The above components are secured to a large HDPE base. Two hollow ballast tubes are anchored beneath the base. The ballast tubes are designed so that pea gravel or sand can be easily added to these tubes during installation.

### DownUnder™ SELF-WEIGHTED AIR SUPPLY TUBING (Drawing on Page 4)

- Over-sized 0.58 inch I.D. for low-pressure drop applications\*
- Heavy-duty wall thickness for durability
- Self-weighted for easy installation
- Kink proof & puncture resistant
- Available in 100 ft. (boxed) & both 200 & 500 ft. (rolls) lengths
- 10-year warranty (best in the industry)

\* DownUnder™ air supply tubing is also available in 0.375 in. I.D. for smaller pond and lake applications

DownUnder™ air supply tubing is constructed of a flexible PVC composite and is self-weighted in order to firmly remain along the pond or lake bottom after the installation. Sections of DownUnder™ tubing are connected together using standard PVC solvent weld cement and ½ inch insert fittings. DownUnder™ air supply tubing has low friction walls for maximizing airflow rates and minimizing air pressure drops. Our DownUnder™ tubing is designed to reduce the overall system pressure requirements and to extend the life of the air compressors. The wall thickness provides long-term durability and protection against kinking and punctures. The air supply tubing remains flexible in cold temperatures allowing for easy year round installations.

# Hydro Logic Products

## Specifications – AirLift 10 HighFlow Aeration System

Page 4

### Drawings

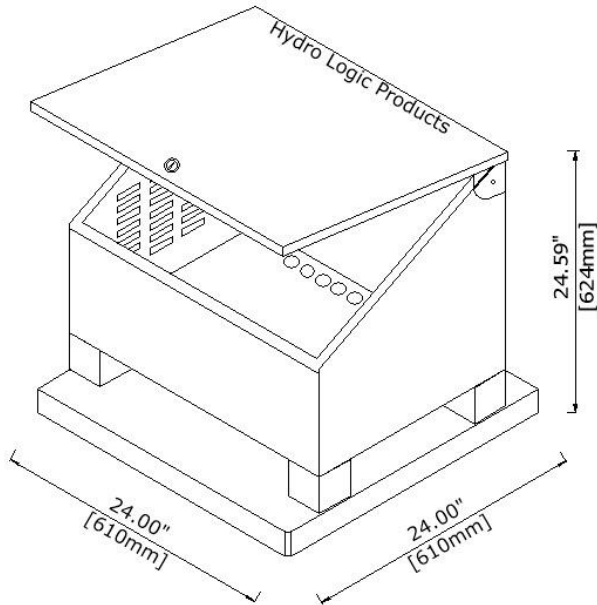

**Air Compressor Cabinet**

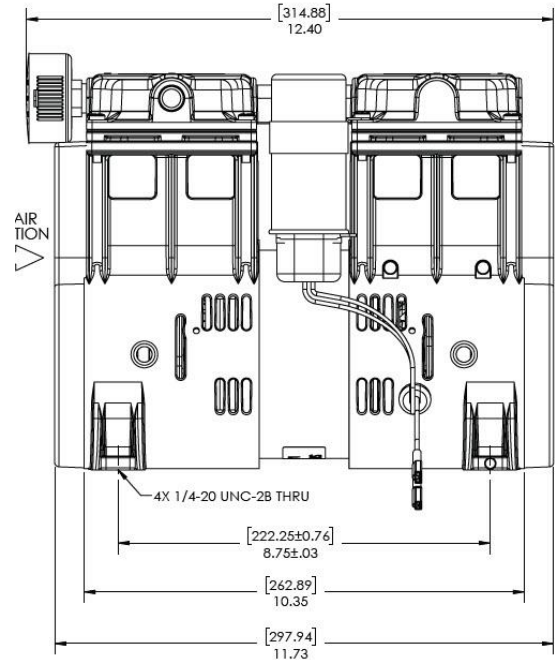

**Dual Piston Air Compressor Side View**

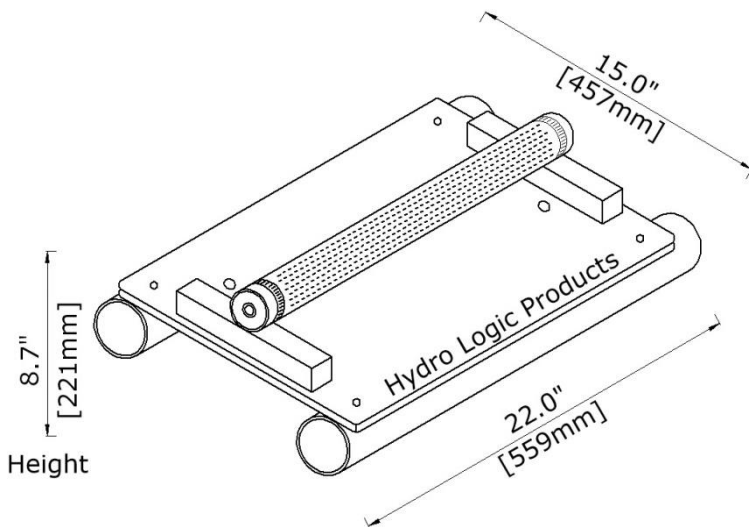

**AirPod Air Diffuser**

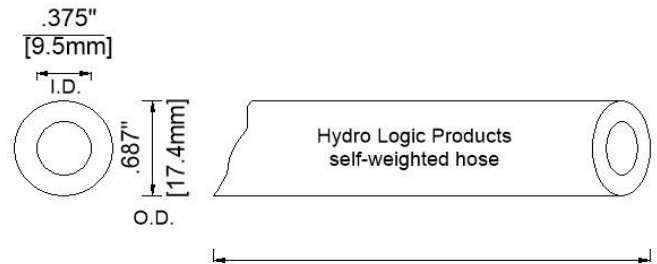

Available in 100ft boxes and 500ft reels.

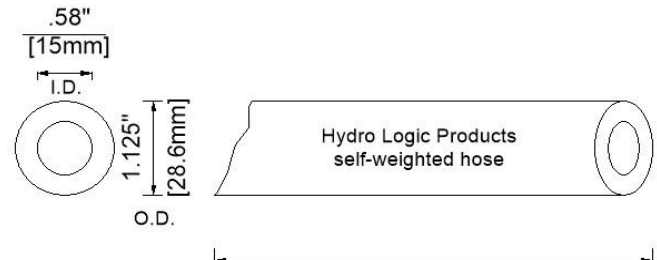

Available in 100ft boxes, 200ft and 500ft reels.

**DownUnder Self-Weighted Air Supply Tubing**

**Important Notice:** Install all electrical equipment in accordance with Article 680 of the National Electrical Code and all local codes. Hydro Logic Products reserves the right to improve and change our aeration system designs and/or specifications without notice or obligation.